

Tula Mild Steel Seat

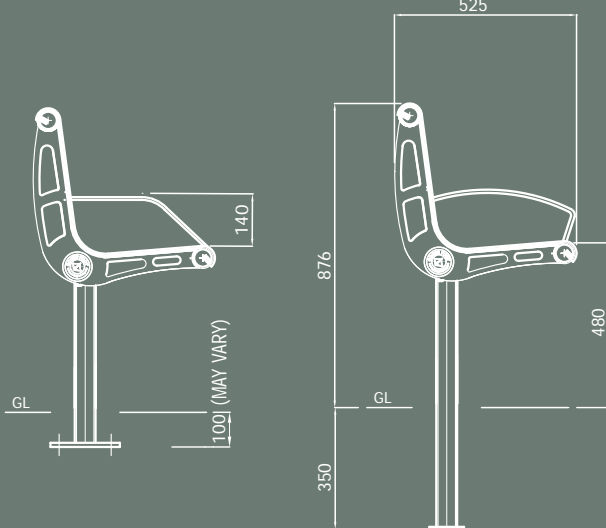
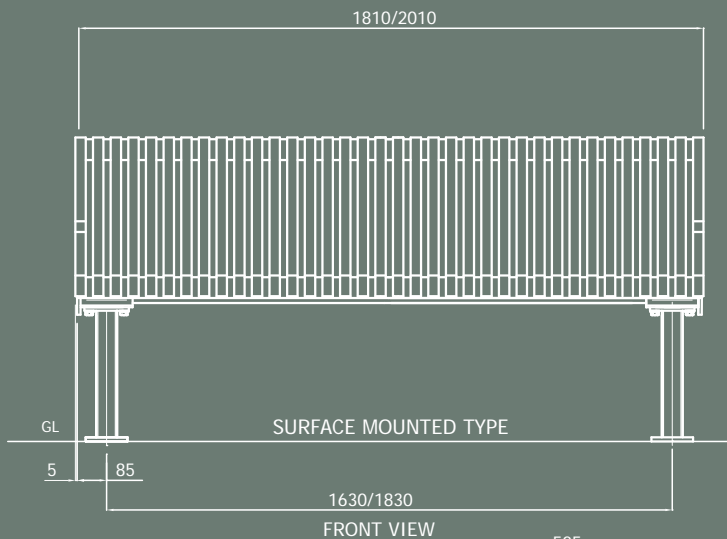

SUB-SURFACE MOUNTED TYPE
TYPICAL ELEVATION
WITH FLORENTINE ARM

SPIGOT MOUNTED TYPE
TYPICAL ELEVATION
WITH MANNHEIM ARM

TECHNICAL DATA

Inspired by the strength and rigidity of 21st century airframe construction, the hot-dip galvanised, colour-coated mild steel Tula seat is engineered to combine rugged all-weather performance with an ergonomic profile that provides excellent support.

The Tula seat can also be fitted with the precision sculpted Florentine or Mannheim-styled arm.

Size Options

1810mm standard length (<i>as shown</i>)	GF5200
2010mm standard length	GF5210
Other lengths to special order	

Variations

A choice of colours from our Standard Range	
Manufactured in satin polished stainless steel	GF5201

Leg Mounting Options

Surface	-01
Spigot	-02
Sub-Surface	-03

Other Options

Arm rests - Mannheim Style (<i>see right photo</i>)	GF501
- Florentine Style (<i>see left photo</i>)	GF502
Memorial plaques	GF510
Seat end logos	GF511

